

LAB
1 Laboratory
 Activity

Balanced Levers

In general, a lever is a bar that is free to turn about a pivot point called a fulcrum. When a lever is balanced horizontally, the following relationship exists:

$$\text{resistance force} \times \text{resistance arm} = \text{effort force} \times \text{effort arm}$$

This equation is called the law of the lever.

You can use the principle of balanced levers to construct a mobile. Each of the dowel rods you will use in constructing your mobile acts as a lever. The point where each string supports a dowel rod is the fulcrum of the lever. The weights that you hang from the dowel rods to keep the lever in balance act on the objects as effort and resistance forces. The distances between the objects and the fulcrum correspond to the effort arm and resistance arm of the balanced lever.

Strategy

You will design and construct a mobile.

You will show that each lever in your mobile obeys the law of the lever.

Materials



string

meterstick

4 wooden dowel rods (one 50 cm long, the others at various shorter lengths)

various objects of different weights (paper clips, keys, etc.)

metric spring scale (calibrated in newtons)

Procedure

1. Tie a piece of string near the center of the 50 cm dowel. Anchor the other end of the string to the tabletop or ceiling, if possible. Allow room below this dowel to add objects to the mobile.
2. Weigh each object that you plan to use in constructing your mobile. Record the weights of the objects in Table 1. Be sure to include the smaller dowel rods when you weigh the objects.
3. Use the string and remaining rods to construct the mobile. You may use any design. However, the main lever (50-cm rod) and any other dowels you use must be balanced horizontally. See Figure 1.
4. When you are finished, measure the distance in mm from each hanging object to the fulcrum of each lever. When recording these distances in Table 2, choose one distance on the balanced lever as the resistance arm and the other as the effort arm. Thus, the weight of the object hanging from the resistance arm is the resistance force. The weight of the object hanging from the effort arm is the effort force.

Figure 1

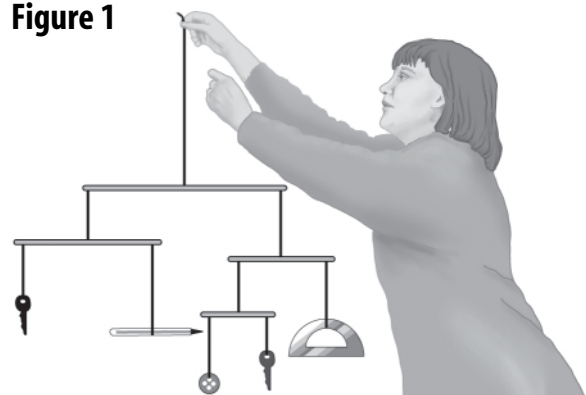

Laboratory Activity 1 (continued)

Data and Observations

For each lever, calculate the product of the resistance force and the resistance arm and the product of the effort force and the effort arm. Record your calculations in Table 2. Use your calculations to support the law of the lever.

Table 1

Object	Weight (N)	Object	Weight (N)

Table 2

Lever	Effort arm (mm)	Effort force (N)	Product (N × mm)	Resistance arm (mm)	Resistance force (N)	Product (N × mm)
A						
B						
C						
D						

Questions and Conclusions

1. A 25-N weight hangs 10 cm to the left of the fulcrum of a lever. A 15-N weight hangs 12 cm to the right of the fulcrum. Is the lever balanced? How do you know?

2. How does the length of string used to hang the objects affect their position on the lever?

Laboratory Activity 1 (continued)

3. When is an equal arm balance an example of a balanced lever?

4. For the balanced levers shown in Figure 2, use the law of the levers to fill in the missing data for **a** and **b**.

Figure 2

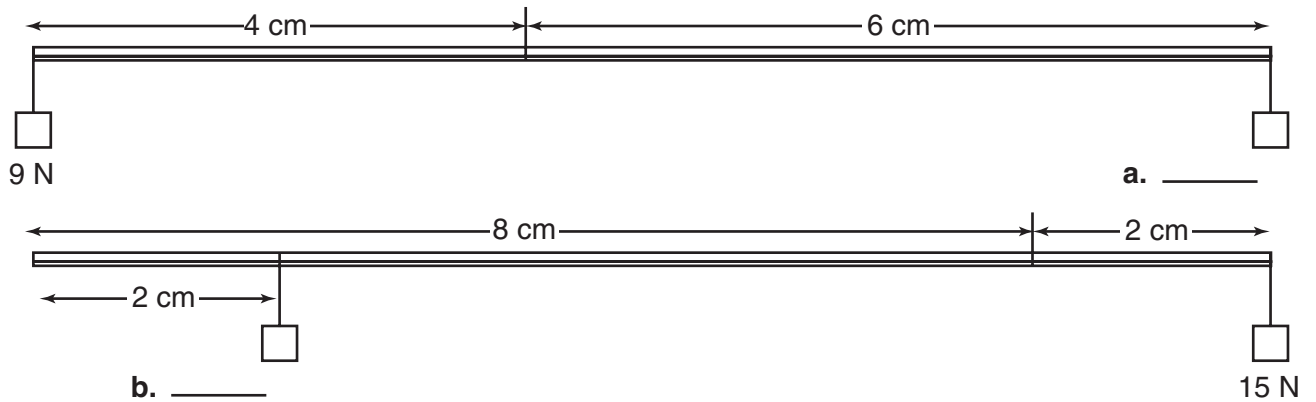

Strategy Check

- _____ Can you design and construct a working mobile?
- _____ Can you show that each lever in your mobile obeys the law of the lever?